

# TECHNICAL INFORMATION

## SPECIAL ANGLE SETTING

When ordering shapes at non-standard angles, please use the diagrams below to eliminate any confusion.  
 - This key way location matches same as amada turret punch press programing method.

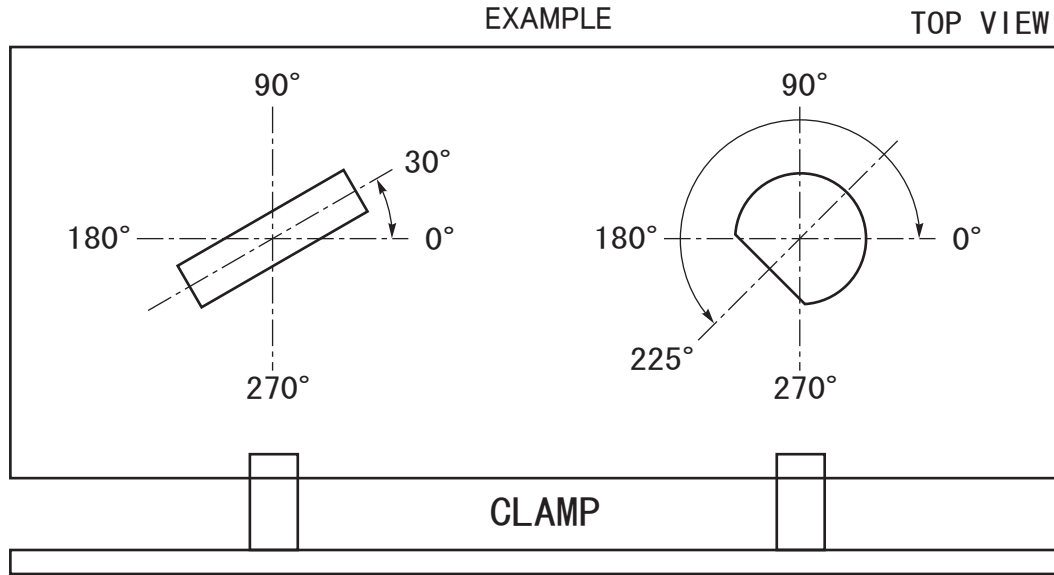

## DIE CLEARANCE

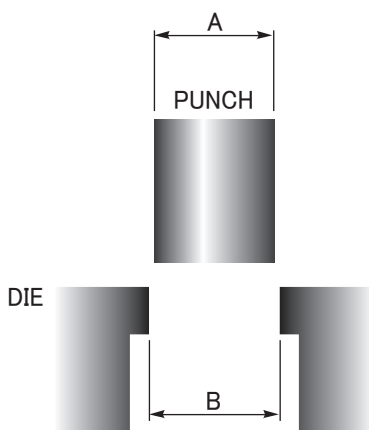

### DIE CLERANCE IS ...

Die clearance is difference between punch diameter and die diameter.

$$\text{Die clearance} = B - A$$

### RECOMMENDED DIE CLERANCE

Die clearance = Material thickness x Clearance Ratio

Material	Clearance Ratio	Material thickness					
		0.5~1.0	1.2	1.5	2.0	2.3	3.2
Mild steel	0.15	0.15	0.2	0.25	0.3	0.4	0.5
Stainless steel	0.2	0.2	0.25	0.3	0.4	0.5	0.6
Aluminum	0.1	0.15	0.15	0.15	0.2	0.25	0.35
Copper	0.1	0.15	0.15	0.15	0.2	0.25	0.35